

## **AWARENESS & USE OF E-RESOURCES ON INFORMATION SEEKING BEHAVIOR OF UNDERGRADUATES AT RAJARATA UNIVERSITY OF SRI LANKA**

**J.S.D. Sewwandi<sup>1,\*</sup> and H.M.B.P. Ranaweera<sup>2</sup>**

*<sup>1,2</sup> Department of Information Systems, Faculty of Management Studies, Rajarata University  
of Sri Lanka, Mihintale, Sri Lanka*

\*Corresponding Author (email: dilinisew98@gmail.com)

### **INTRODUCTION**

ICT advancements shift information from print to electronic, increasing the value of e-resources (Karunaratna, 2014). Modern libraries aim to acquire more digital information resources to meet the diverse needs of students, teachers, scientists, and researchers efficiently (Partap & Ranga, 2021). Sri Lankan universities have established electronic archives and web-based resources, leading to exceptional utilization of e-resources by students (Wijethunga, 2017). The shift from print to electronic resources has transformed academic libraries, meeting the needs of researchers and information seekers. E-resources provide flexibility and cost-effectiveness, requiring librarians to inform users about their usage (Puneeth, 2021).

ICT changes teaching, learning, and information retrieval (Wijethunga, 2017). e-resources offer benefits over print materials, impacting user behavior and expanding learning opportunities. Awareness of resources and services is essential for practical use, as faster and easier access to information influences user behavior towards e-resources (Umar, 2019). According to Ahmad et al. (2019), many studies conducted on using e-resources reveal various challenges library users face. Factors such as lack of infrastructure, user education, awareness programs, language barriers, and limited IT skills restrict the utilization of e-resources. Low publicity, inadequate training, access restrictions, poor internet connection, insufficient computers, power outages, and limited searching skills hinder the full utilization of e-resources. These issues negatively impact access and usage of e-resources among academics and students (Kumar *et al.*, 2021).

Limited studies have focused on students' information-seeking behavior about e-resources, particularly in the Sri Lankan university context (Munasinghe, 2014). The importance of understanding the problems faced by users when utilizing online information services is emphasized for better user service (Ali, 2005). Previous studies have primarily focused on postgraduate students, researchers, and teachers, with limited studies conducted on undergraduate students' use of electronic resources (Ruzegea & Msonde, 2021). The present research aims to explore the awareness and use of e-resources and their impact on the information-seeking behavior of undergraduates at Rajarata University in Sri Lanka.

### **METHODOLOGY**

The population of this study is 3<sup>rd</sup> year and 4<sup>th</sup> year undergraduates in the Faculty of Management Studies, Rajarata University of Sri Lanka. The reason for selecting them as the population is that they are mostly engaging with information seeking with research and heavy academic work. The population is 934 undergraduates. The sample is selected from the population in a stratified sampling method, and the sample size is 274. This quantitative research is based on first-hand data and uses a deductive approach. The data is analyzed using the following techniques with SPSS software. Descriptive analysis, correlation analysis, and regression analysis were used to analyze the data.

Figure 1 below indicates the conceptual diagram developed based on a comprehensive literature review.

**Figure 1**  
*Conceptual Framework*

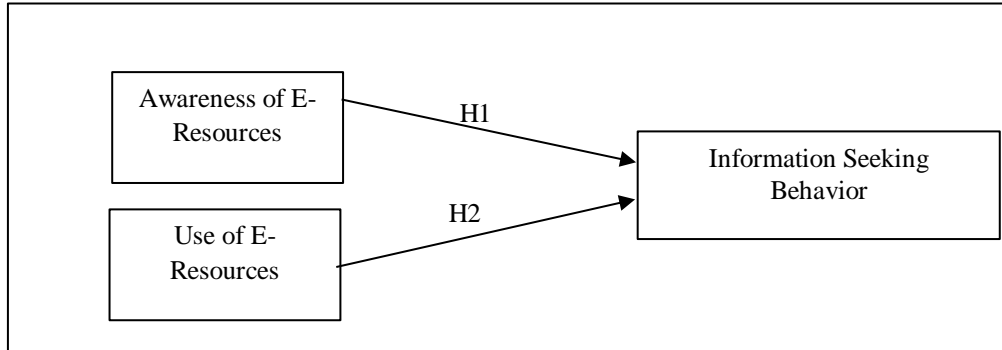

The researcher developed hypotheses based on literature evidence.

*H<sub>1</sub>*: There is an impact of awareness of e-resources on the Information seeking behaviour of undergraduates at the Rajarata University of Sri Lanka.

*H<sub>2</sub>*: There is an impact of the use of e-resources on the information-seeking behaviour of undergraduates at the Rajarata University of Sri Lanka.

**RESULTS AND DISCUSSION**

The Cronbach Alpha value was checked to measure the internal consistency. This value should be more than 0.6 (this means 60% reliability) and identified that all three variables were internally consistent. Hence, none was removed from the scale. According to Table 1, the Cronbach Alpha value of each variable was greater than 0.9, indicating that the internal consistency of variables is good.

Descriptive statistics was used to explain the prevailing situation of variables. The overall mean value of awareness of e-resources (3.5517) indicates that respondents believe that awareness of E-resources is critical in information-seeking behavior. The overall mean value of the use of E-resources (3.8923) indicates that the participants of this study have moderately agreed with the use of e-resources.

**Table 1**  
*Values of reliability analysis and mean*

Variable	Mean	Cronbach’s Alpha Value
Awareness of E-resources	3.551	0.948
Use of E-Resources	3.892	0.978
Information Seeking Behaviour	3.986	0.978

The correlation analysis in Table 2 showed that the awareness of e-resources had a strong positive correlation (0.723, sig. value = 0.000) with information-seeking behavior. Similarly, using e-resources had a strong positive correlation (0.921, sig. value = 0.000) with information-seeking behavior. These results indicate a strong relationship between the

variables. The Pearson coefficients, which measure the strength of the relationships, were all between 0-9, indicating a good fit in the dataset.

The criteria for conducting a regression analysis were met, and the database was deemed strong enough to obtain reliable results to test the hypotheses.

**Table 2**

*Results of Pearson Correlation Analysis*

	Information Seeking Behaviour (A)	Awareness of E-Resources (B)	Use of E-Resources (C)
A	1		
B	.723**	1	
C	.921**	.782**	1

N= 261, \*\*P<0.01

The regression analysis results are shown below in Table 3. The adjusted R square denotes the multiple correlation coefficients representing all variables; 0.846 is the coefficient of determination. The regression model may account for 84.6 percent of the undergraduate's information-seeking behavior. The proportion of variance in the dependent variable (Information-seeking Behavior) that the independent factors can explain is known as awareness of E-resources and use of e-resources.

**Table 3**

*Results of Regression Analysis (Model Summary)*

Model	R	R Square	Adjusted R Square	Std. Error	Durbin-Watson
1	0.921 <sup>a</sup>	0.847	0.846	0.277	1.992

a. Predictors: (Constant), Use\_of\_EResources, Awareness\_of\_EResources  
b. Dependent Variable: Information\_Seeking\_Behavior

The use of the e-resources coefficient (0.799, P- 0.000) reveals that it positively impacts information-seeking behavior. These findings back up the study's second hypothesis (H<sub>2</sub>). This suggests that for every unit increase in the use of e-resources, there is a 0.799 times unit increase in undergraduates' information-seeking behavior.

**Table 4**

*Hypotheses Testing*

Hypotheses	Regression		Decision
	$\beta$	P	
H <sub>1</sub> : There is an impact of awareness of e-resources on the information-seeking behavior of undergraduates at the Rajarata University of Sri Lanka.	0.008	.817	Not supported
H <sub>2</sub> : The use of e-resources has an impact on the information-seeking behavior of undergraduates at the Rajarata University of Sri Lanka.	0.799	.000	Supported

When looking at hypotheses, only one is accepted. The first hypothesis (H<sub>1</sub>) showed that only correlation has a positive relationship with undergraduate information-seeking behavior. According to regression analysis results, awareness of e-resources did not significantly impact undergraduates' information-seeking behavior. Therefore, the hypothesis couldn't be accepted.

## CONCLUSION AND IMPLICATIONS

The main objective of this study was to examine awareness of e-resources and the use of e-resources on the information-seeking behavior of undergraduates at Rajarata University of Sri Lanka. This result indicates that awareness does not significantly impact the information-seeking behavior of undergraduates at the Rajarata University of Sri Lanka. The results of this study also show a significant positive impact on the use of e-resources towards the information-seeking behavior of undergraduates at Rajarata University of Sri Lanka.

Future researchers using online resources and how people search for information could widen their studies by looking at additional factors like how skilled people are with technology and their attitudes. They might also use different methods like surveys and discussions to get a complete picture. To overcome the limits of their studies, they could include more people in their research or look at different types of universities. Watching how people's behavior changes over time could show how online resources affect them in the long run. They could also see if things like age or comparing online to traditional materials play a role. The findings of this study provided practical contributions for undergraduates, academics, and future researchers as it revealed empirically how awareness and use of e-resources influence information-seeking behavior. The results and recommendations of this study can be used to manage university students' use of e-resources better and improve their information-seeking behaviour.

**Keywords:** Awareness of e-resources, e-resources, information seeking behaviors, use of e-resources

## REFERENCES

- Ahmad et al. (2019). Usage and Perception of E-Resources by Undergraduate Students: A Case Study of Government Degree College Baramulla- J&K. *Library Philosophy and Practice (e-journal)*.
- Ali, N. (2005). The use of electronic resources at IIT Delhi Library; a study of search behaviours. *The Electronic Library*.
- Karunarithna, H. (2014). Use of Electronic Resources by Law Degree Students at Anuradhapura Regional Centre of the Open University of Sri Lanka. *Journal of the University Librarians Association of Sri Lanka*.
- Kumar et al. (2021). Awareness and information seeking behavior of undergraduate students of the university in digital environment-A Systematic Review. *Scholarly Journal*.
- Puneeth, B. (2021, Jan -Mar). Awareness and Use of E-Resources by the Library Users in University of Agricultural Sciences GKVK, Bangalore: A Case Study. *International Journal of Library and Information Studies*.
- Munasinghe, P. G & Dayarathna, C. K. D. (2014). Information Seeking Behavior of Undergraduates of Sri Lanka in Digital/ Online Environment. <http://ssrn.com/abstract=2535331>Electroniccopyavailableat:<https://ssrn.com/abstract=2535331>Electroniccopyavailableat:<http://ssrn.com/abstract=2535331>
- Partap, B., & Ranga, M. (2021). Awareness and Use of e-Resources at Chandigarh College of Architecture, Chandigarh, India: A Study. *Library Philosophy and Practice* . <https://digitalcommons.unl.edu/libphilprac>

- Ruzegea, M., & Msonde, S. (2021). University Students' E-Resource Usage: Predictors, Problems and Practical Implications. In *International Journal of Education and Development using Information and Communication Technology (IJEDICT)* (Vol. 17, Issue 2).
- Soni, N. K., Gupta, K. K., & Shrivastava, J. (2018). Awareness and usage of electronic resources among lis scholars of Jiwaji University, Gwalior: A survey. *DESIDOC Journal of Library and Information Technology*, 38(1), 56–62. <https://doi.org/10.14429/djlit.38.1.11524>
- Umar, J. F. (2019, September). Assessment on the use of electronic resources by undergraduates of library and information science students ahmadu bello university zaria. *Academia*. Retrieved from <https://www.academia.edu/23173868/>
- Wijethunga, P. (2017). Usage of electronic resources by librarians of Sri Lankan universities. *Annals of Library and Information Studies*, 64, 21–27.